

FA



mitsubishi FUSO TRUCK & BUS CORPORATION

*Light-Footed and
Powered for Profit*





Technology

Fuel-Efficient Common Rail Engine Plus Euro 4/5 SCR

The fuel-efficient, common rail, direct injection engine with four valves per cylinder delivers ample power and torque while lowering operating costs. Advanced Euro 4/5 Selective Catalytic Reduction (SCR) injects AdBlue®, a specially formulated urea solution, into exhaust gases to reduce emission of nitrogen oxides.

4D37
DIESEL 3.907L

100kW
2,500rpm

420Nm
1,500rpm

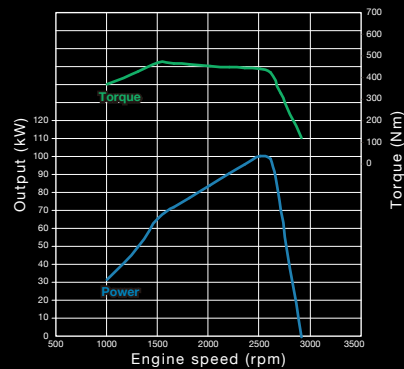

E-Viscous Fan

Intermittent operation of E-Viscous fan reduces load on engine, improving fuel efficiency.

Smooth, Durable Six-Speed Transmission

The six-speed (6F, 1R) overdrive transmission combines multiple synchronizer rings and a cable-type shift mechanism to make shifting smoother and easier. The large diameter clutch plate and organic clutch material increase durability.

Intelligent Instrument Cluster

The LED panel makes vital information more visible, and a buzzer will sound if the engine overheats. The Trip Mileage Indicator makes it easy to monitor distance traveled, average speed and fuel consumed.

Engine RPM Throttle Control

RPM is set according to demand.

Fuel Theft Control

Meshed grill at the mouth of the fuel tank prevents fuel theft between trips.

Comfort

A Great Place to Work

The comfortable cabin is equipped with fully adjustable seats, a tilt-and-telescoping steering wheel, smooth transmission, lined roof, side trim, handy console pocket and roof storage. All of these play a role in reducing driver fatigue and increasing productivity.

Aerodynamic Cab Design

Aerodynamic design reduces wind resistance and lowers fuel cost. It also reduces noise and keeps the cabin quieter.

Modern Turn Signal Design

Turn signal lamps offer a fusion of function, fit and aesthetics.

LED Lamp

Updated and more durable design for greater visibility in all types of light and weather conditions.

Music System

Enhanced audio entertainment system provides a richer and more enjoyable audio experience.

Exceptional Exterior

Striking design ensures that your fleet always stands out from the competition.

MDT 914R 3760WB, 4250WB, 4800WB SPECIFICATIONS

Model	914R 3760WB	914R 4250WB	914R 4800WB
Drive type	RHD		
Crew	3(1+2)		

DIMENSIONS (mm)

Wheelbase	3760	4250	4800
Overall length	6865	7465	8075
Overall width	2200		
Overall height	2405		
Tread	front	1790	
	rear	1690	

WEIGHTS (kg)

Kerb weight *	3255	3350	3380
Max. GVW (tech)	9600		
Max. GCW (tech)	Not applicable		

CALCULATED PERFORMANCE

Max. speed (km/h)	100
Max. running gradeability (tan θ)(%)	28

ENGINE

Model	4D37 100, Emission Euro IV
Type	Compressed Ignition, 4 Stroke, Direct injection, Turbo charged diesel engine
Max. output	100 kW (140Hp) @ 2500 rpm
Max. torque	420 Nm @ 1500 rpm
Alternator	24V, 45 A

DRIVE LINE

Clutch	330mm, Hydraulic control, Diaphragm spring, Single-Dry plate with CSC (Concentric Slave Cylinder)		
Transmission	MO36S6, Mechanical, 6 forward + 1 reverse		
gear ratios	Gear 1st - 6th: 5.400 - 3.657 - 2.368 - 1.465 - 1.000 - 0.711 Rev: 5.400		
Final reduction gear	Fully floating, single reduction, Hypoid gears		
ratio	5.13 : 1		

CHASSIS

Axle capacity (kg)	front	3600
	rear	7400
Tire	front	8.25 R16 (Radial, Tube)
	rear	8.25 R16 (Radial, Tube)
Suspension	front	Type: Semi elliptical, Multi leaf springs - Shock absorber: Hydraulic double acting
	rear	Type: Semi elliptical, Multi leaf springs - Shock absorber: Not applicable
Brake	service	Full air S-Cam Dual circuit with ABS
	parking	Pneumatically operated spring brake actuator acting on rear wheels
	exhaust and engine	Exhaust brake
Fuel tank capacity (L)		200
Electrical system	batteries	2x12V, 75Ah

*Complete Cab chassis vehicle(without driver & rear body) with: ●Coolant ●Fuel tank filled with fuel of 90% of its capacity ●Spare wheel ●Standard tool kit ●Wheel chock
●All liquids to ensure correct functioning of vehicle ●Warning triangle(if provided) ●Jack and jack rod

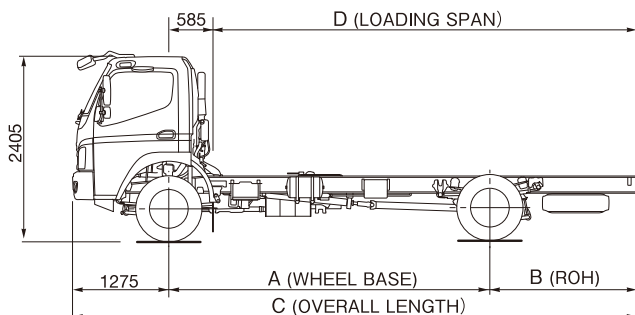
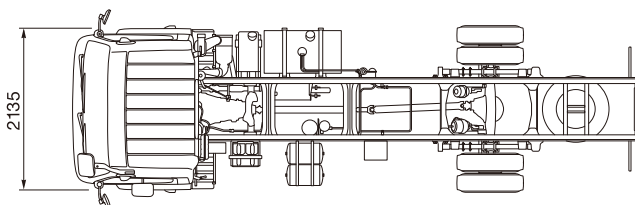

	914R 3760WB	914R 4250WB	914R 4800WB
A (Wheelbase)	3760	4250	4800
B (RoH)	1950	1940	2000
C (Overall length)	6865	7465	8075
D (Loading span)	5005	5605	6215

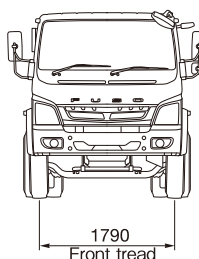

COLOR VARIATION

Standard Arctic White